

www.rhopointcomponents.com E: sales@rhpointcomponents.com

M210 Milli-Ohmmeter

- 5 mA Test Current
- 4 Terminal Input
- UKAS Calibration Certificate

M210 Milli-Ohmmeter

This instrument is a portable digital meter to measure low resistances over the range 0.001Ω to 200Ω . A high degree of accuracy is achieved by utilising a four terminal input to eliminate errors caused by test lead length.

The instrument is small and light weight and is used easily in one hand with only an ON button to operate. It has auto-ranging, auto-decimal point and auto-powerdown after three minutes. It has long battery life and is powered by a single PP3 or MN1604 battery.

One of the most important features of the Milli-Ohmmeter is its low (5mA) test current. This ensures that the contact being tested is not 'cleaned' by the test current which can happen when higher test currents are used. This 'cleaning' of the contact under test leads to erroneous measurements.

Some typical applications:

- Relay, switch and connector contacts
- PC-plated through holes
- PC track resistance
- Transformer and motor windings
- Ring circuit testing
- Earth conductor continuity
- Wire-wrapped and solder joints
- RFI shielding and coil resistance
- Network cabling
- Aircraft bonding check

In the four-terminal "Kelvin" configuration four wires are used to connect the circuit under test to the instruments.

One pair of wires carries current generated by the instrument, the other pair connect to the voltage-measuring circuit.

The current circuit is low impedance, the voltage circuit high impedance. When connected a current flows through the component or circuit under test and the voltage drop across the test points is measured.

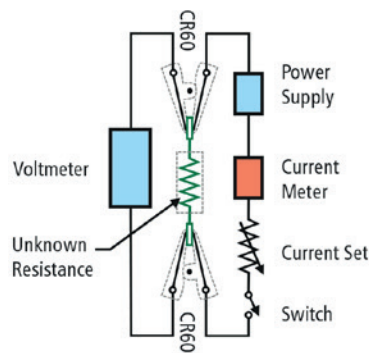

Features:

- ✓ 0.1% accuracy
- ✓ Only 5mA test current
- ✓ Single push button operation
- ✓ Auto switch-off after three minutes
- ✓ 20 hours continuous operation (from standard PP3 battery)
- ✓ Auto-ranging
- ✓ Four terminal input
- ✓ Lightweight and portable

Accurate readings every time

Spring clip connectors

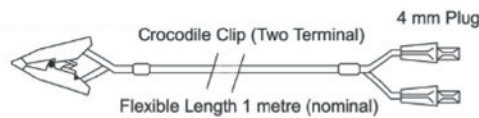

1. Plug either black plug into either black socket in the top of the instrument and red plugs into red sockets.
2. Clip leads to circuit or component to be tested. Ensure that both faces of clip make good electrical contact.
3. Press the ON button to read resistance.

Included as standard.

Probe and contact connector

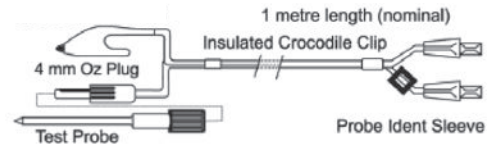

1. Insert plugs into their respective sockets as illustrated. The outer plugs form the current circuit via the clips. The inner plugs (with yellow bands) connect the probes in the voltage measuring circuit.
2. Clip leads to circuit under tester.
3. Press ON button to read resistance when probes are in contact with the circuit.

Optional extra, supplied as pair of connectors with probes. Part Code: B210-110.

Interpreting the display

1. The Milli-Ohmeter will read directly in ohms or in milli-ohms.
2. Fluctuating readings displayed. Check that the clips are making good contact with the circuit under test, then look for the cause of intermittency, e.g. dry solder joint, oxydised or corroded terminals; slight mechanical movement of the component(s) in the circuit under test should quickly reveal the source of the problem.
3. Flashing "1" indicates that resistance in circuit exceeds 200 ohms.
4. "LO-BAT" displayed indicates low battery

Replace cover

Slide down the cover at the rear, bottom of the instrument. Fit new battery 9 volt pp3 (MN1604 or equivalent). Replace cover.

The ratio between the current and the voltage drop is calculated by the instrument using Ohm's law ($R=E/I$) to display the result in ohms. Four clips would normally be required for connection but this could be tedious so a form of clip is used with the Milli-ohmeter.

The jaws are moulded in robust plastic and inset into each jaw face is a copper / silver inlay contact; these are insulated from each other by the plastic mouldings. One contact face on each clip is connected to the current-generating circuit, the other face is connected to the voltage-measuring circuit. In this way four wires are connected instantly by two clips.

The resistance of the connecting wires plays no part in the measuring so no "backing-off" is required as would be the case if a multi-meter were to be used for the same measurement.

Specifications

Milli-Ohmmeter	
Ranges	1.999 Ω , 19.99 Ω , 199.9 Ω
Increments	0.001 Ω , 0.01 Ω , 0.1 Ω
Accuracy	\pm 0.1% of range
Zero offset	\pm 0.001 Ω
Maximum V	1.4V
Maximum A	5mA
Temperature drift	0.013%/ $^{\circ}$ C of lowest range
Display	3 1/2 digit L.C.D.
Battery	9V (PP3 MN1604 or equivalent)
Operating temperature	5 $^{\circ}$ C to 35 $^{\circ}$ C
Weight (including case and leads)	510gms
Dimensions (in case)	H:15cm, W:14.5cm, D:4.5cm
Dimensions (out of case)	H:15cm, W:8cm, D:3.8cm

Included as standard	
Milli-Ohmmeter	M210
Set of standard test leads with spring clip connectors	
Protective carry case	
Instruction leaflet	
UKAS calibration certificate	

Optional extras	Part number
Probe and contact connector lead set	B210-110
Replacement test lead set (spring clip connector)	B210-100



M210



B210-100



B210-110

The M210 Milli-Ohmmeter is manufactured by Rhopoint Instruments, UKAS calibrated by Rhopoint Metrology and supplied to RS Components by Rhopoint Components.