

PART NUMBER

CSMRLVGXXA

COMPONENT SPECIFICATION

ISSUE 2



Component Specification For Hermetically Sealed, Radiation-Hard Latching Solid State Relay

Features	Applications
<ul style="list-style-type: none"> ▪ Low on-state resistance ▪ Selection of Operating Current and Voltage ▪ SPST, SPDT, DPST, DPDT ▪ Full Military temperature range -55°C - +125°C ▪ Military and Space Screening ▪ Compatible with μC Drive ▪ Internally Isolated ▪ Output Currents up to 9A 	<ul style="list-style-type: none"> ▪ Designed for 10 to 50V_{DC} Bus Application ▪ Space Systems/Satellites ▪ Space Battery Management Systems ▪ Bus Control ▪ Aerospace Power Distribution ▪ Power Isolation and Control

DESCRIPTION

ISOCOM Latching Solid State Relays are designed to replace existing electro-mechanical relays (EMR). The CSMRLVGXXA is available in the single pole single throw (SPST), single pole double throw (SPDT), double pole single throw (DPST) and double pole double throw (DPDT) configuration. They are resilient to damage from shock and immune to contact-related problems (arcing, contamination) that are associated with mechanical equivalents. They are also lightweight in comparison to the EMR. Coupling between the input, output and power bus stages offers an effective isolation up to 500V. The latch and reset input stages are designed to directly interface with standard microcontrollers (μ C), requiring low current (< 10mA) with 3.3V or 5V logic. This device offers various operating voltage ranges from 10 to 50V with current capabilities up to 9A. Furthermore, it is featured in a 12 Pin Flatpack Power Package where each pin is isolated with a glass seal. This package comes with a gold plate finish and solder dip options available.



ISOCOM Limited is AS9100 certified for the design and manufacture of electronic and optoelectronic components.

For sales enquiries, or further information, please contact our sales office at –

ISOCOM Limited • 2 Fern Court • Bracken Hill Business Park • Peterlee • County Durham • SR8 2RR• United Kingdom

Email: sales@isocom.uk.com • Tel: +44 (0)191 416 6546

STANDARDS

The following specifications have been complied with in the manufacturing of this product –

Aerospace Compliance Standards

AS9100D & ISO 9001:2015 – Design & Manufacture of Electronic and Optoelectronic Components (*Ref GB15/92780*)

Military Compliance Specifications

MIL-PRF-28750 – General Specification for Solid State Relay

Military Compliance Standards

MIL-STD-883 – Test Method Standard Microcircuits

SCREENING INFORMATION

Our LSSR range can be screened to MIL-PRF-28750, applying test methods from MIL-STD-883. Please contact us for more information relating to the applicable screening processes.

FUNCTIONAL DIAGRAMS

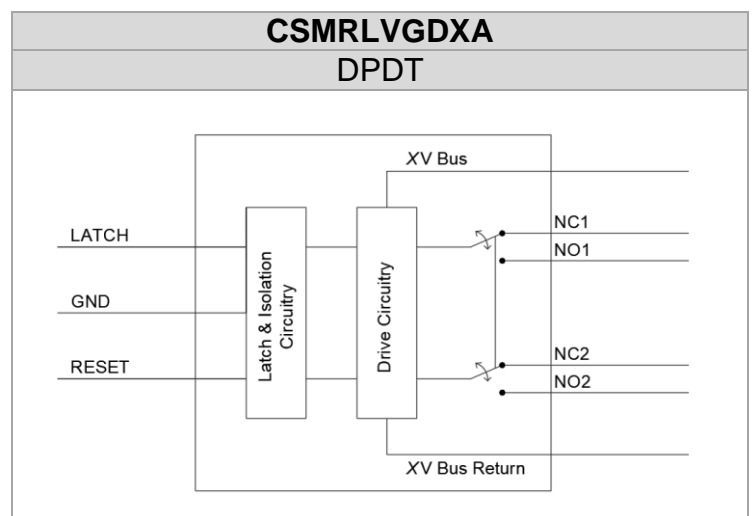
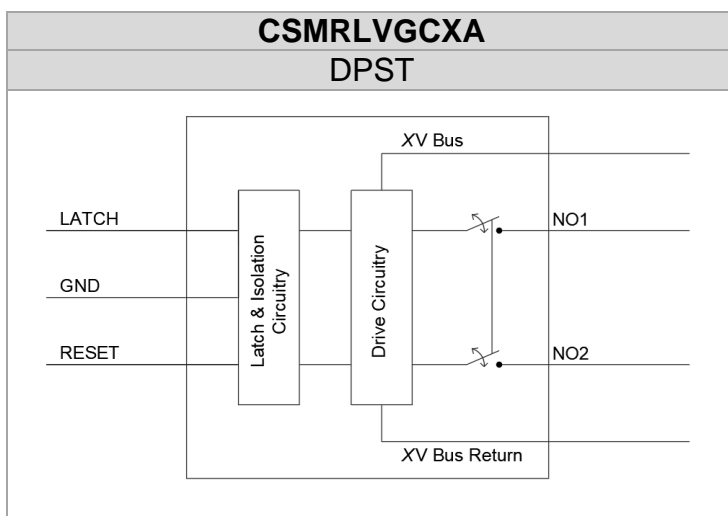
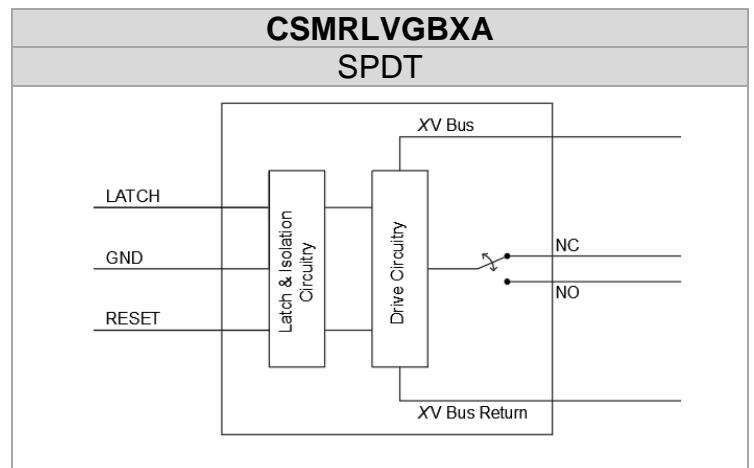
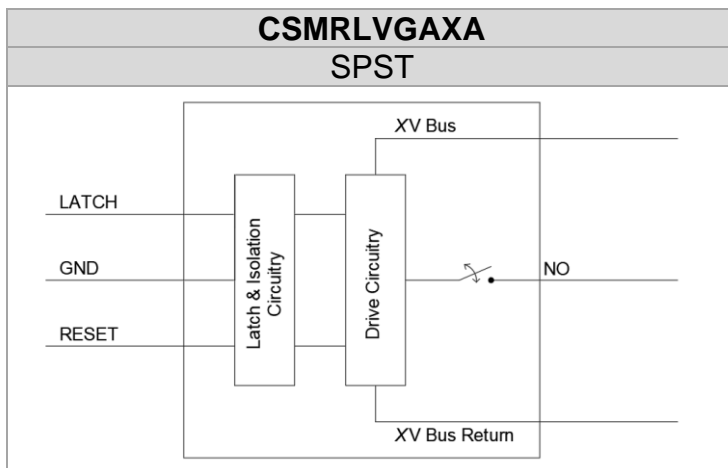

For sales enquiries, or further information, please contact our sales office at –

ISOCOM Limited • 2 Fern Court • Bracken Hill Business Park • Peterlee • County Durham • SR8 2RR • United Kingdom

Email: sales@isocom.uk.com • Tel: +44 (0)191 416 6546

ABSOLUTE MAXIMUM RATINGS

T_A = 25°C U.O.S

Storage Temperature	-65° to +150°C
Operating Temperature	-55° to +125°C
Soldering Temperature	260°C
Continuous Output Current per relay – I _o	See Selection Guide *
Output Voltage- V _o	See Selection Guide +10%
V _{LATCH}	7V
V _{RESET}	7V
I _{LATCH}	15mA
I _{RESET}	15mA
Input-to-Output Isolation Voltage	↑500 V _{DC}
XVBus	50V

*Current Limited by Package

ELECTRICAL CHARACTERISTICS

T_A = -55°C to +125°C U.O.S

Parameter	Symbol	Test Conditions	Min	Typ	Max	Units
Input						
Latch voltage	V _{Latch}	I _{Latch} = 10mA	3	5	-	V
Reset voltage	V _{Rst}	I _{Rst} = 10mA				
Latch Current	I _{Latch}	V _{Latch} = 5V	7	10	-	mA
Reset Current	I _{Rst}	V _{Rst} = 5V				
Latch/Reset reverse breakdown voltage	B _{VR(Latch)} B _{VR(Rst)}	I _R = 10 μA	5	-	-	V
Latch pulse duration	PW _{Latch}	V _{Latch} = 5V	40	-	-	μs
Reset pulse duration	PW _{Rst}	V _{Rst} = 5V	40	-	-	μs
Output						
XVBus current	I _{Bus (Latched)}	X = 10V TO 50V, mode = Latch	-	8	-	mA
	I _{Bus(Unlatched)}	X = 10V TO 50V, mode = Reset	-	1.5	-	mA
Output current	I _o	X = 10V TO 50V	See selection guide (Page 7)			A
Output on state resistance (per output)	R _(On)					mΩ
Output leakage Current	I _{oL}					-
Coupled						
Input-to-output isolation breakdown voltage ⁽¹⁾	V _{I-O}	I _{I-O} in to out = 1μA, T _A = 25°C	-	-	500	V
Latch time (NO Latch) ⁽²⁾	T _{PL(NO)}	X = 10V TO 50V, I _{oX} = See selection guide	-	950	-	μs
Latch time (NC Latch) ⁽²⁾	T _{PL(NC)}		-	150	-	
Reset latch delay (NO to reset) ⁽²⁾	T _{PR(NO)}		-	250	-	
Reset latch delay (NC to reset) ⁽²⁾	T _{PR(NC)}		-	150	-	

Notes:

- (1) Inputs shorted together; outputs shorted together
- (2) See propagation timing delay measurements
- (3) For data on SOA please contact sales at ISOCOM Ltd

For sales enquiries, or further information, please contact our sales office at –

ISOCOM Limited • 2 Fern Court • Bracken Hill Business Park • Peterlee • County Durham • SR8 2RR • United Kingdom

Email: sales@isocom.uk.com • Tel: +44 (0)191 416 6546

PROPAGATION TIMING DELAY MEASUREMENTS

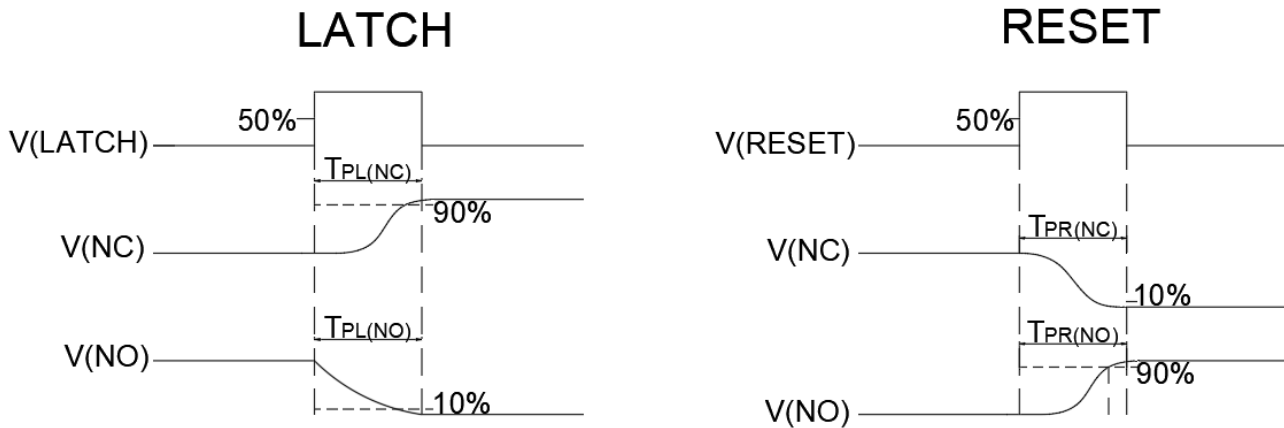

Switching Characteristics (Note: All Signals Measured with Respect to XV Bus Return)

TRUTH TABLE

Bus Voltage	on	on	on	on	on	on	off	on
Latch	0	1	0	0	0	1	X	0
Reset	0	0	0	1	0	0	X	0
NO status	Open	Closed	Closed	Open	Open	Closed	Open	Open
NC status	Closed	Open	Open	Closed	Closed	Open	Open	Closed

On initial powerup the LSSR is in its default condition. The normally open (NO) and normally closed (NC) outputs are open and closed respectively. Upon receiving a short input pulse to the LATCH input, the NO and NC terminals become closed and open circuit respectively. The device will then remain in the latched condition indefinitely or until a short input pulse to the RESET returns the outputs to their default conditions. Additionally, if the XV bus line is off while the LSSR is in the LATCH state, the device outputs automatically return to their default conditions upon the power reinstatement.

For sales enquiries, or further information, please contact our sales office at –

ISOCOM Limited • 2 Fern Court • Bracken Hill Business Park • Peterlee • County Durham • SR8 2RR• United Kingdom

Email: sales@isocom.uk.com • Tel: +44 (0)191 416 6546

APPLICATIONS

APPLICATION 1

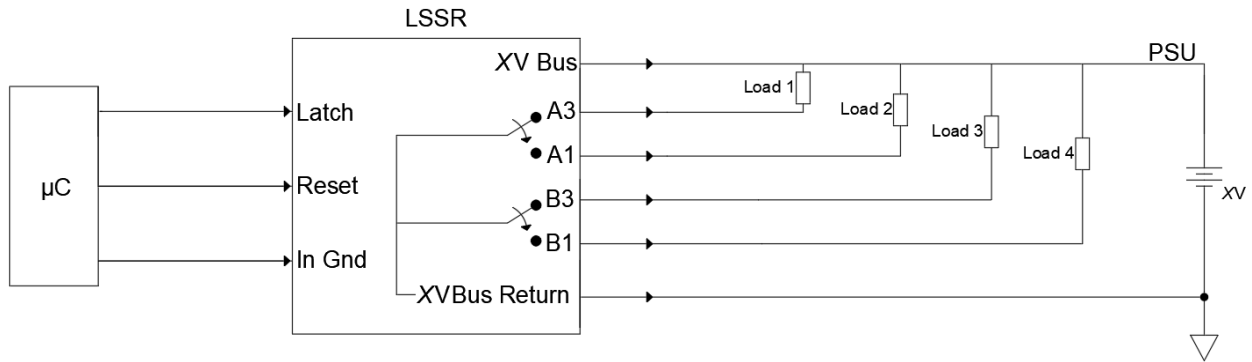

Notes:

- For low side switching
- All loads connected to XV
- XV Bus Return has the sum of current from all loads and XV PSU
- Waveforms below measured at points A1/B1 (NO) and A3/B3 (NC) outputs with respect to XV Bus Return

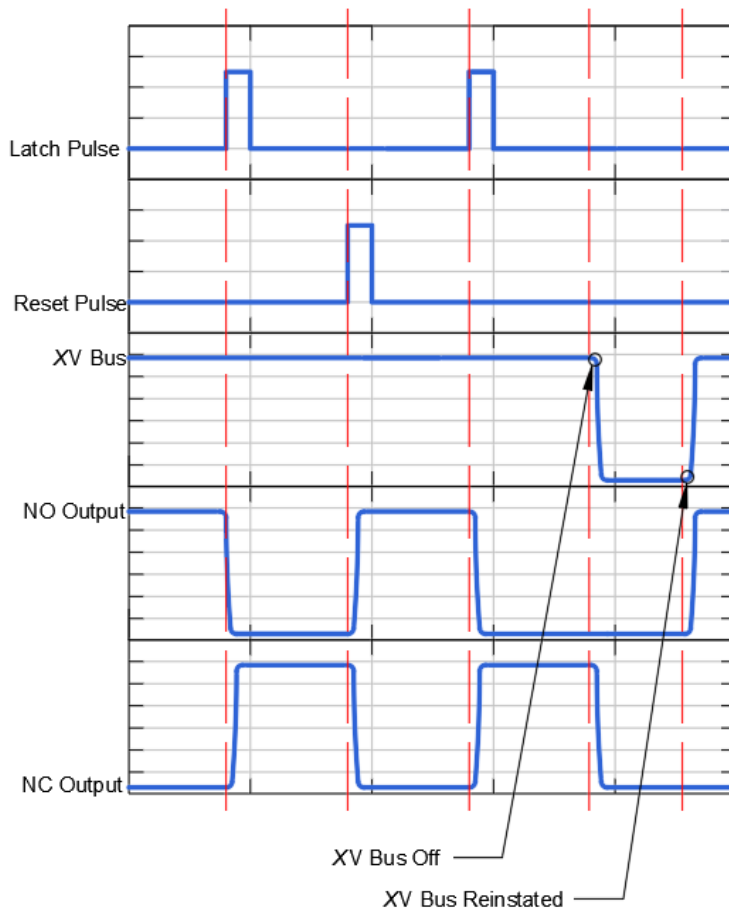

For sales enquiries, or further information, please contact our sales office at –

ISOCOM Limited • 2 Fern Court • Bracken Hill Business Park • Peterlee • County Durham • SR8 2RR • United Kingdom

Email: sales@isocom.uk.com • Tel: +44 (0)191 416 6546

APPLICATION 2

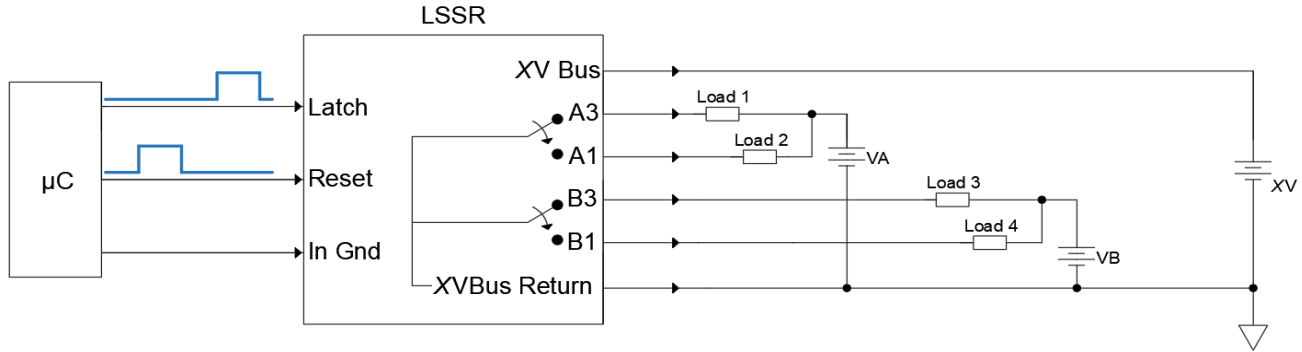

Notes:

- For low side switching
- Can have an XV power supply for a virtual V_{CC}
- VA and VB can be independent supplies (and lower than XV)
- Can also be expanded to independent PSUs on the loads of A3, A1, B3 and B1
- All output supplies must share the same ground
- XV Bus Return has the sum of currents from VA, VB and XV
- Waveforms below measured at points A1/B1 (NO) and A3/B3 (NC) outputs with respect to XVBus Return

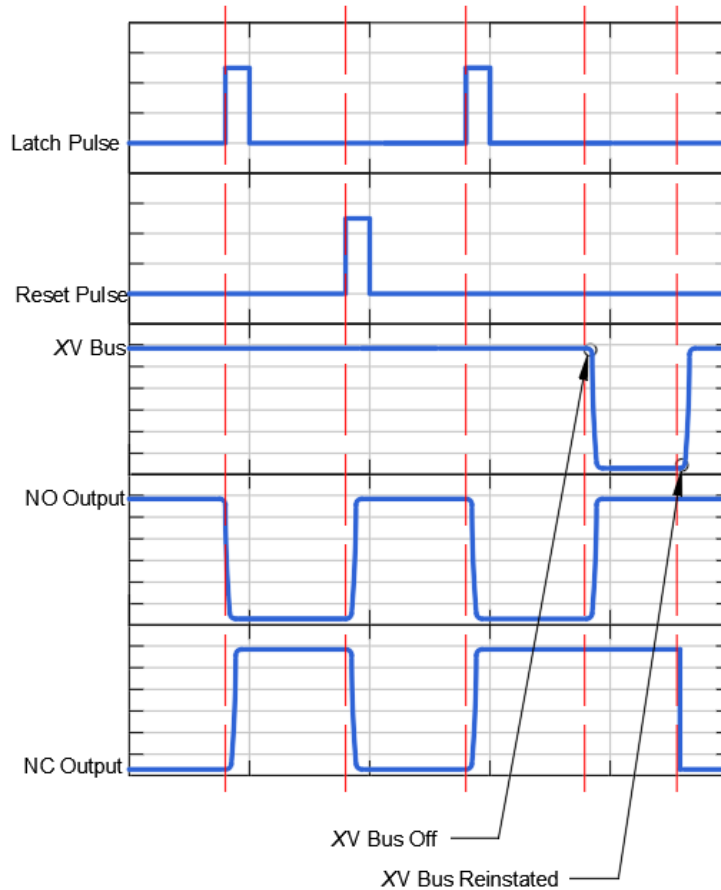

For sales enquiries, or further information, please contact our sales office at –

ISOCOM Limited • 2 Fern Court • Bracken Hill Business Park • Peterlee • County Durham • SR8 2RR • United Kingdom

Email: sales@isocom.uk.com • Tel: +44 (0)191 416 6546

SELECTION GUIDE

Bus Voltage (V)	I _D (A)	R _(ON) (TYP) (mΩ)
10-50	1 3 5 9	10

ORDERING PARTS

CSMRLVG X X A

Part Reference	Circuit	Current (A)	Package Type
CSMRLVGXXA	A (SPST)	1	Power Package 12 Pin Flatpack
	B (SPDT)	3	
	C (DPST)	5	
	D (DPDT)	9	

PACKAGE STYLES AND CONFIGURATION OPTIONS

Package	Power Package 12 Pin Flatpack
Lead Style	-
Channels	Optional
Common Channel Wiring	-
ISOCOM Part Number and Options	
Commercial	CSMRLVGXXA
Defense Screen Level	CSMRLVGXXA/L2
Space Screen Level	CSMRLVGXXA/L2S
Standard Gold Plate Finish	Gold Plate
Solder Dipped	Option #20

For sales enquiries, or further information, please contact our sales office at –

ISOCOM Limited • 2 Fern Court • Bracken Hill Business Park • Peterlee • County Durham • SR8 2RR • United Kingdom

Email: sales@isocom.uk.com • Tel: +44 (0)191 416 6546

DEVICE MARKING

FRONT OF DEVICE

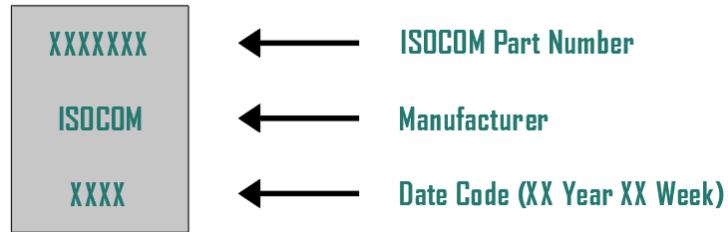

BACK OF DEVICE

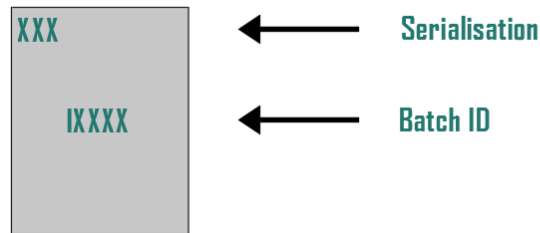

FOR SPACE SCREENED PARTS ONLY

OUTLINE DRAWINGS

Power Package 12 Pin Flatpack

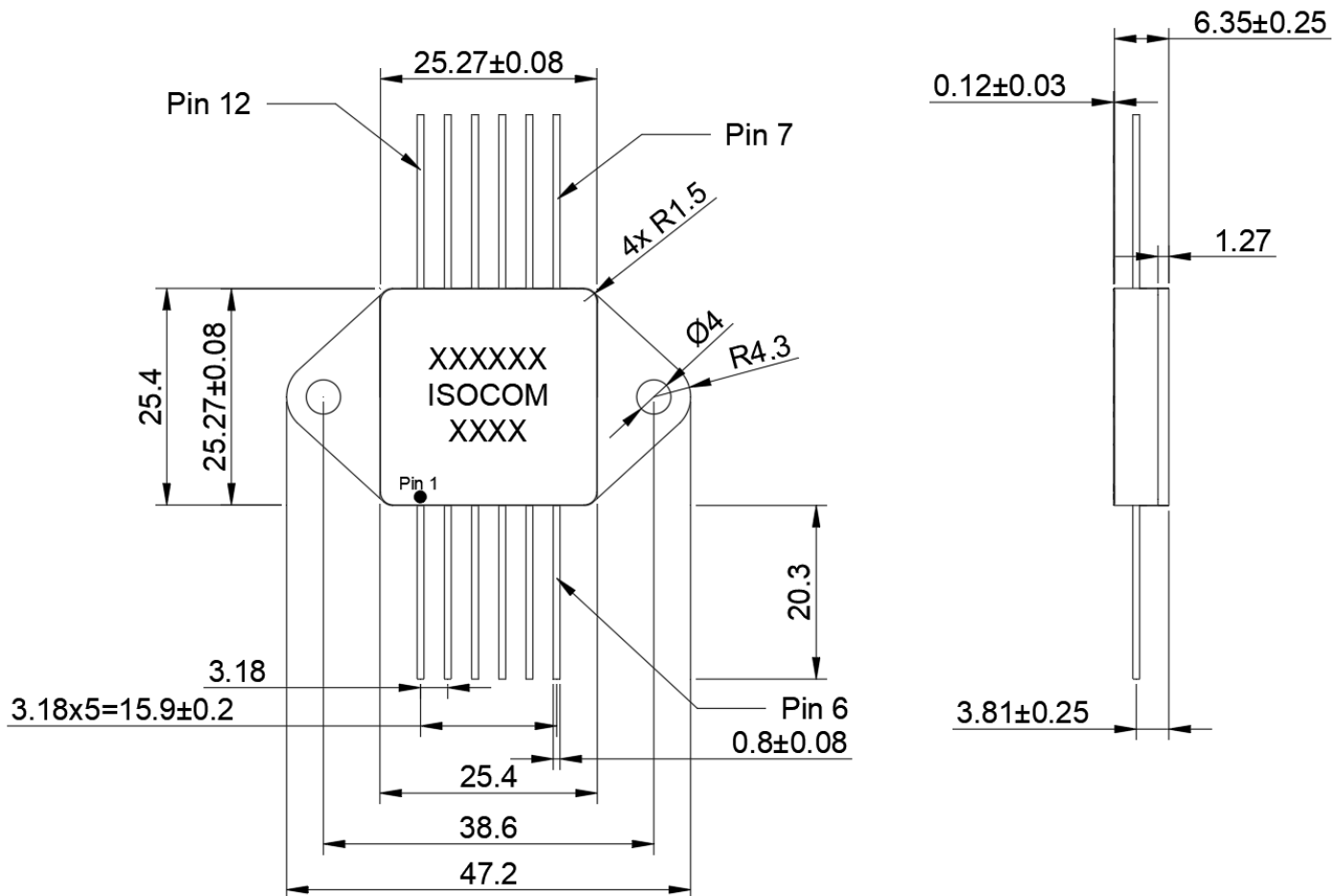

For sales enquiries, or further information, please contact our sales office at –

ISOCOM Limited • 2 Fern Court • Bracken Hill Business Park • Peterlee • County Durham • SR8 2RR • United Kingdom

Email: sales@isocom.uk.com • Tel: +44 (0)191 416 6546

PIN OUT INFORMATION

Pin Number	Pin Function			
	SPST	SPDT	DPST	DPDT
1	XVBus	XVBus	XVBus	XVBus
2	Reset	Reset	Reset	Reset
3	GND	GND	GND	GND
4	Latch	Latch	Latch	Latch
5	-	-	NO2	NO2
6	-	-	NO2	NO2
7	-	-	-	NC2
8	-	-	-	NC2
9	NO1	NO1	NO1	NO1
10	NO1	NO1	NO1	NO1
11	-	NC1	-	NC1
12	-	NC1	-	NC1
Case	XVBus Return	XVBus Return	XVBus Return	XVBus Return

DISCLAIMER

The information provided on the datasheet is for preliminary and general information only. We do not warrant that the information contained on the datasheet is suitable for your intended use, nor do we accept responsibility for loss suffered as a result of reliance by you upon the accuracy or currency of information contained on the datasheet. In particular, you should not make any investment or commercial decision on the basis of the information contained on the datasheet. You should obtain independent professional advice and make your own further enquiries before making any investment or commercial decision or taking any further action in any way related to the information contained on the datasheet.

We are not aware of any inaccuracy in the information contained on the datasheet. However, we do not warrant the accuracy, adequacy or completeness of such information.

We reserve the right to remove or alter any of the information contained on the datasheet at any time. However, we do not guarantee the currency of the information contained on the datasheet, nor do we undertake to keep the datasheet updated.



ISOCOM Limited is AS9100 certified for the design and manufacture of electronic and optoelectronic components.

For sales enquiries, or further information, please contact our sales office at –

ISOCOM Limited • 2 Fern Court • Bracken Hill Business Park • Peterlee • County Durham • SR8 2RR • United Kingdom

Email: sales@isocom.uk.com • Tel: +44 (0)191 416 6546