

1 Description

The RedRock® RR123-1H02-612 is a digital magnetic sensor-switch ideal for use in small battery-powered applications such as portable medical devices. It is based on patented Tunneling Magnetoresistance (TMR) technology with seamless CMOS integration.

The RR123-1H02-612 features an operate sensitivity of 7G (0.7mT), with an omnipolar magnetic field response. It offers a voltage range from 1.0V up to 3.6V, ideal for applications that use single cell 1.5V batteries. It has the lowest average current drain (20nA) for an active magnetic sensor, operating under 2Hz and with a temperature range from -40°C up to +85°C. This sensor/switch can be used to efficiently source up to 20mA of current to an application circuit. It also has a Latch Control Pin (LCP), which gives the option to keep the output in a given state regardless of any changes in magnetic field.

2 Features

- ▶ Operate sensitivity of 7G
- ▶ Lowest Average Current of 20nA
- ▶ Latch Control Pin Locks Output Voltage in Current State
- ▶ Supply Voltage range of 1.0V – 3.6V
- ▶ Can Efficiently Source Up to 20mA with a Low PMOS $R_{DS(on)}$
- ▶ Omnipolar Push-Pull Response
- ▶ Operating Frequency of 1.0Hz
- ▶ Temperature Rated up to 85°C
- ▶ RoHS & REACH Compliant

3 Applications

- ▶ Switch Battery Power to Circuit
- ▶ Wake-Up μ Processor
- ▶ Proximity Detection
- ▶ Door & Lid Closure Detection
- ▶ Portable Medical Devices

Device Information

Part Series	Package	Body Size (mm)	Temp Rating °C
RR123-1H02-612	LGA-4	1.45 x 1.45 x 0.44	-40 to +85

Device Packages



Functional Block Diagram for Digital Push-Pull Output

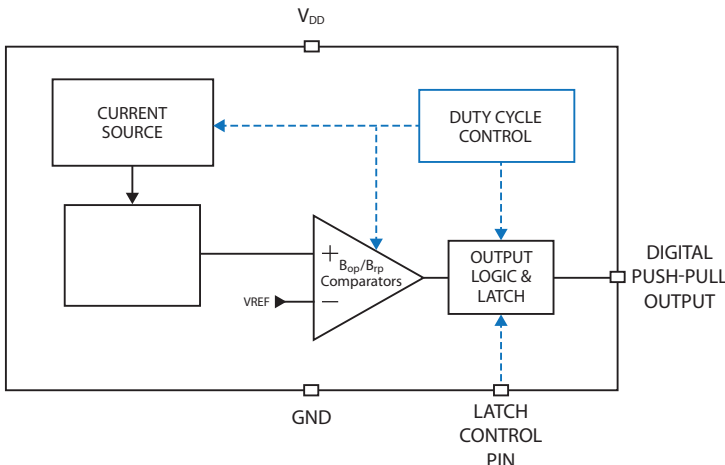

Ordering Information

RR123-1 H 0 2-6 1 2	
Series	1 = Omnipolar
Magnetic Polarity Response	0: 1.0
Magnetic Sensitivity (G)	H: Op 7, Rel 3
Clock Frequency (Hz)	0: 1.0
Package	2: LGA-4
Output Response	1: Active Low
Supply Voltage (V)	6: 1.0 – 3.6
Temp Rating (°C)	2: -40 – +85

4 Specifications

4.1 Absolute Environmental Ratings^{1,2}

Parameters	Units	Min	Typ	Max
Operating Temperature (T _{OP})	°C	-40		+85
Storage Temperature (T _{STG})	°C	-65		+150
Junction Temperature (T _J)	°C			+125
Soldering Temperature (3 cycles, 1 min.) (T _{SOL})	°C			+260
ESD Level Human Body Model per ANSI/ESDA/JEDEC JS-001	V	±4000		
ESD Level Charged Device Model (CDM) per JEDEC Spec. & JEDEC JS-002	V	±500		
Junction-to-Ambient Thermal Resistance (LGA-4)	°C/W		165	
Maximum Magnetic Field Exposure (B _{MAX})	G			±3000

4.2 Absolute Electrical Ratings^{1,2}

Parameters	Units	Min	Typ	Max
Supply Voltage (V _{DD})	V	-0.3		3.6
Voltage at Sensor Output Pin	V	-0.3		V _{DD} + 0.3
Input and Output Current (I _{IN} /I _{OUT})	mA			±25

Notes:

1. Exceeding Absolute Ratings may cause permanent damage to the device.
2. Unless otherwise specified, all characteristics are measured at 25°C.



ESD Note: This product uses semiconductors that can be damaged by electrostatic discharge (ESD). When handling, proper ESD precautions should be taken to avoid performance degradation or loss of functionality. Damage due to inappropriate handling is not covered under warranty.

4 Specifications (cont.)

4.3 Operating Electrical Characteristics for RR123-1H02-612¹

Parameters	Units	Min	Typ	Max
Supply Voltage (V_{DD})	V	1.0	1.5	3.6
Power-On Time (t_{ON})($V_{DD} > V_{UVLO-RISE}$)	Sec.			2.0
Power Gating Time (t_{PG})	ms		1	3
Peak Power-On Current ($I_{DD-START}$)	μA		60	100
Peak Current (output transition) ($V_{DD}=3.6V$)	mA		7	
Output Source Current (I_{SOURCE}) ⁴	mA			20
Output Source $R_{DS(ON)}$ (PMOS), $V_{DD}=1.4V$ to $1.8V$, $T_A=+10^{\circ}C$ to $+40^{\circ}C$ ⁴	Ω		5	10
Output Sink Current (I_{SINK}) ⁴	μA			13
Output Sink $R_{DS(ON)}$ ⁴	Ω			140
Output Voltage (High) (V_{OH}) ($I_{OUT} = 15mA$)	V	0.91		3.55
Output Voltage (Low) (V_{OL}) ($I_{OUT} = 50\mu A$)	V			0.2
Under Voltage Lockout Threshold Rising V_{DD} ($V_{UVLO-RISE}$)	mV	856	945	1000
Under Voltage Lockout Threshold Falling V_{DD} ($V_{UVLO-FALL}$)	mV	796	868	919
Under Voltage Lockout Hysteresis ($V_{UV-HYST}$)	mV	60	77	92
Switching Frequency (f_{SW})	Hz	0.5	1.0	2.0
Temperature Drift of f_{SW} ($-40 - 85^{\circ}C$)	%	-50		50
Sensitivity of f_{SW} with respect to V_{DD}	%	-20		20
Active Time Peak Current ($I_{DD-PEAK}$)	μA			200
Active Mode Time (t_{ACT})	μs		35	
Idle Mode Current ($I_{DD-IDLE}$) (No sampling of B)	nA		6	
Idle Mode Time (t_{IDLE})	Sec.	0.5	1.0	2.0
Average Supply Current @ $V_{DD}=1.0V$, $f_{SW}=1.0Hz$ (I_{DD-AVG}) ³	nA		10	
Average Supply Current @ $V_{DD}=1.5V$, $f_{SW}=1.0Hz$ (I_{DD-AVG}) ³	nA		11	
Average Supply Current @ $V_{DD}=3.6V$, $f_{SW}=1.0Hz$ (I_{DD-AVG}) ³	nA		20	
Latch Control Pin (LCP) Input Low Voltage	V	0		$V_{DD} * 0.3$
Latch Control Pin (LCP) Input High Voltage	V	$V_{DD} * 0.6$		V_{DD}

Notes:

1. Unless otherwise specified, $V_{DD} = 1.0V$ to $3.6V$, $T_A = -40^{\circ}C$ to $+85^{\circ}C$.
Typical values are $V_{DD} = 1.5V$ and $T_A = +25^{\circ}C$.
2. Conditions: $B_{HYST} = |B_{OP} - B_{RP}|$
3. Conditions: $t=10$ seconds.
4. Please refer to Section 6.2: Application - Power Switching



ESD Note: This product uses semiconductors that can be damaged by electrostatic discharge (ESD). When handling, proper ESD precautions should be taken to avoid performance degradation or loss of functionality. Damage due to inappropriate handling is not covered under warranty.

4 Specifications (cont.)

4.4 Magnetic Operating Characteristics for RR123-1H02-612¹

Parameters	Units	Min	Typ	Max
Operate Point (B _{OPN})	G	5	7	10
Operate Point (B _{OPS})	G	-10	-7	-5
Release Point (B _{RPN})	G	2	3	6
Release Point (B _{RPS})	G	-6	-3	-2
Hysteresis (B _{HYST}) ²	G	3	4	4

- Notes:**
- Unless otherwise specified, V_{DD} = 1.0V to 3.6V, T_A = -40°C to +85°C.
Typical values are V_{DD} = 1.5V and T_A = +25°C.
 - Conditions: B_{HYST} = | B_{OP} - B_{RP} |



ESD Note: This product uses semiconductors that can be damaged by electrostatic discharge (ESD). When handling, proper ESD precautions should be taken to avoid performance degradation or loss of functionality. Damage due to inappropriate handling is not covered under warranty.

4.5 Undervoltage Lockout (UVLO) and Sensor Startup Timing Diagram

Assuming Applied Magnetic Field Exceeds Sensor's Operate Threshold (i.e., B > B_{OPN} or B < B_{OPS})

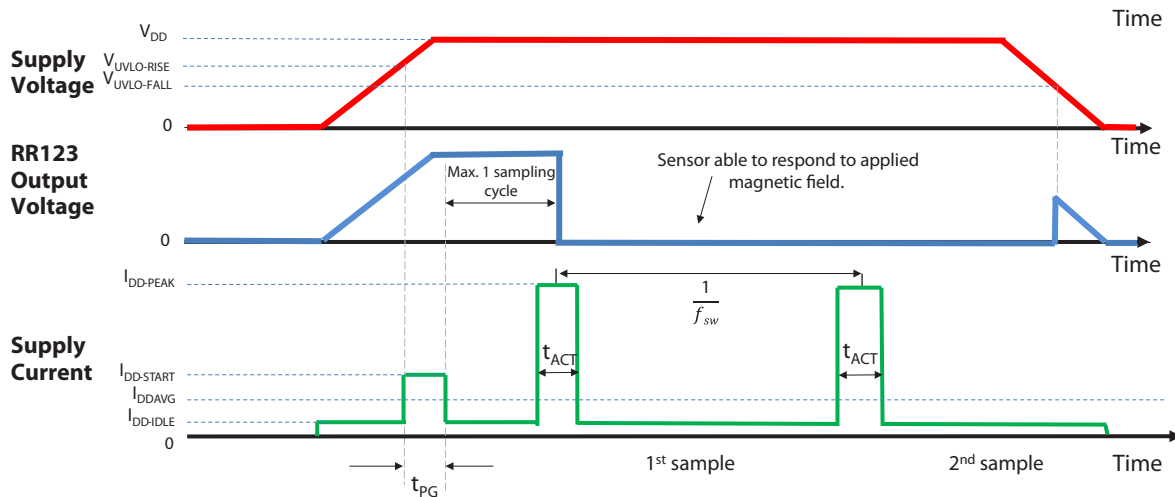

The Undervoltage Lockout (UVLO) function ensures reliable operation of the RR123-1H02-612 and prevents the device from exhibiting unpredictable behavior when the Supply Voltage (V_{DD}) is too low. When first powered ON, the device will not begin normal operation until the applied V_{DD} exceeds the V_{UVLO-RISE} threshold. Similarly, when the device is powered OFF, it will stop its normal operation once V_{DD} drops below the V_{UVLO-FALL} threshold. As shown above, when V_{DD} is below the Rising/Falling UVLO thresholds, the sensor's output will be set to a Logic HIGH state (i.e., Output Voltage tracks V_{DD}).

The RR123-1H02-612 also features a Power Gating function for keeping current consumption as low as possible by shutting down internal circuits that are only used during its startup phase. This function is enabled after the time interval t_{PG} which is between 1ms and 3ms after the sensor exits UVLO mode. Once the sensor is fully operational, it can take up to one full sampling cycle ($\frac{1}{f_{sw}}$) before it takes its first sample of the magnetic field.

5 Graphs - Typical Magnetic & Electrical Characteristics

5.1 Typical Magnetic Characteristics

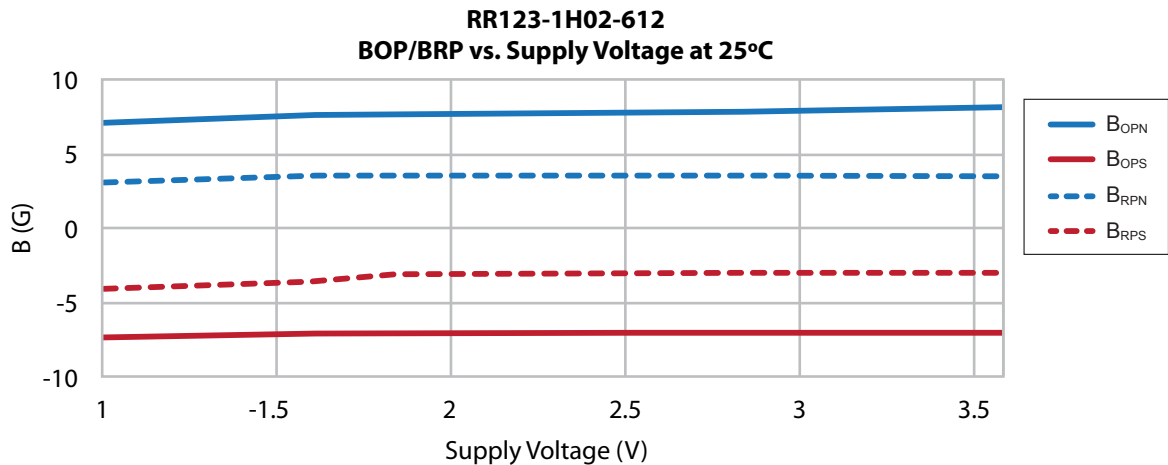
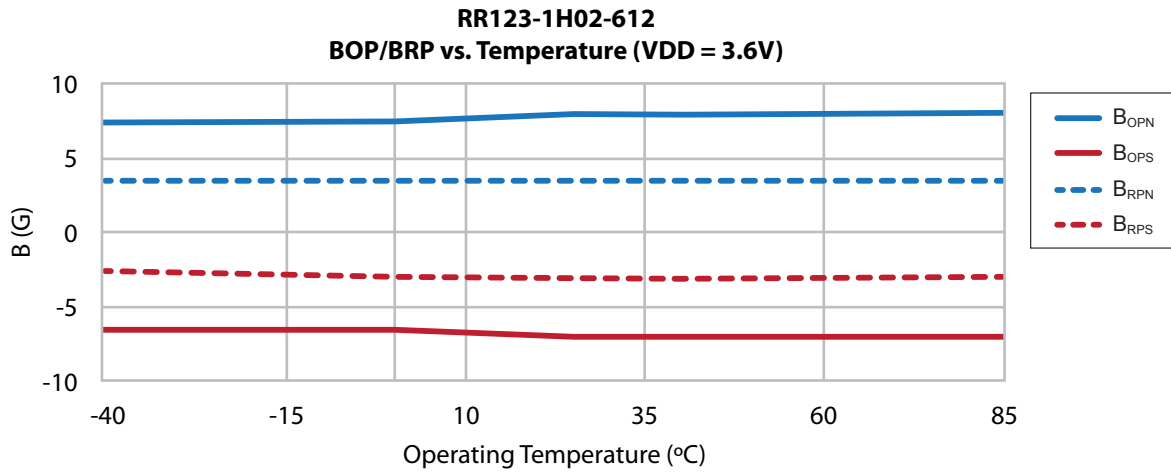
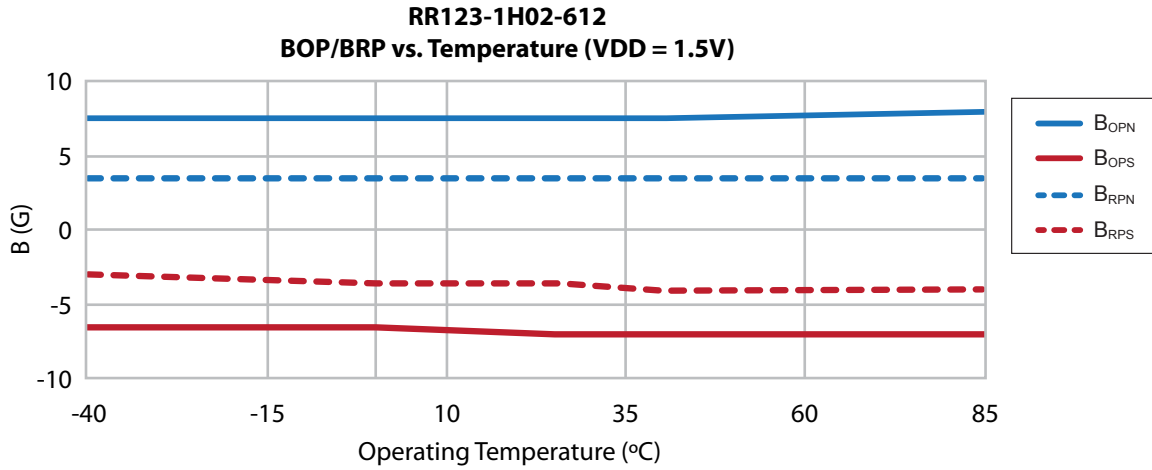

5 Graphs - Typical Magnetic & Electrical Characteristics

5.2 Typical Electrical Characteristics

$C_{DD} = 1.0 \mu\text{F}$ (unless otherwise specified)

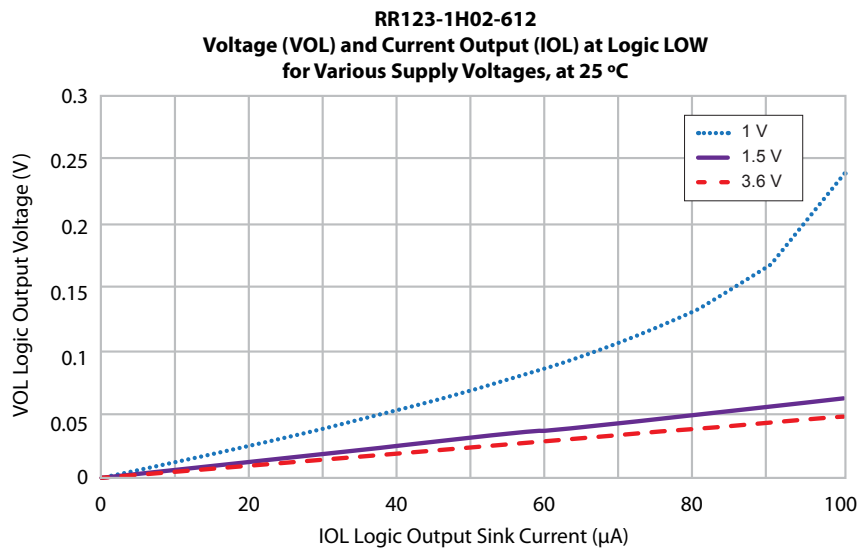
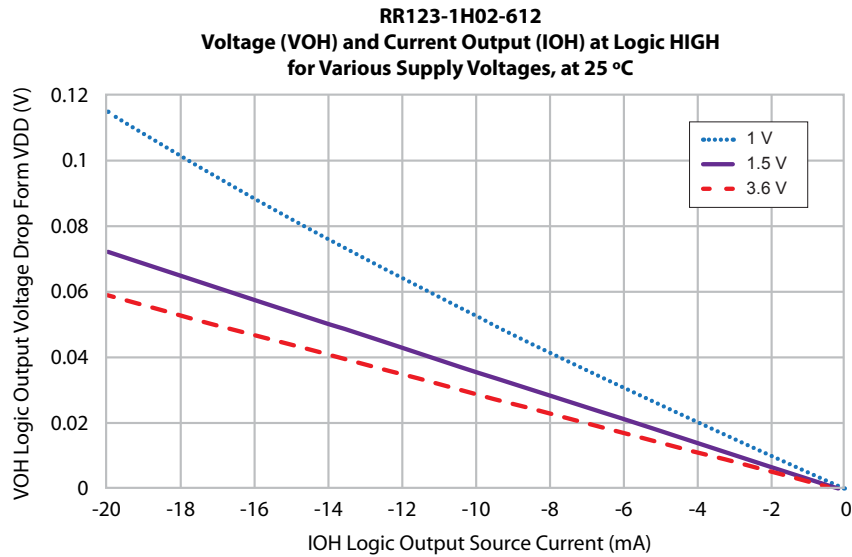
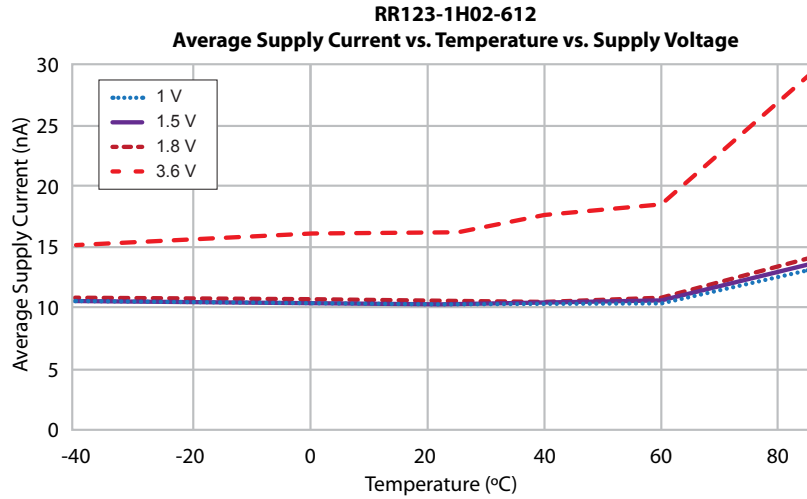

6 Magnetic Response

For more information please contact Coto Technology at www.cotorelay.com.

6.1 Axis of Sensitivity

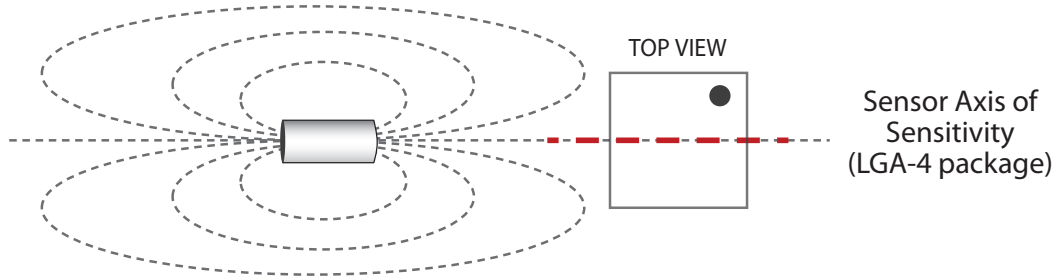

Note: The most straightforward way of aligning a magnet with a TMR sensor is by lining up the magnet's magnetization axis with the sensor's Axis of Sensitivity (as shown above). However, there are many other alignments and orientations that will also achieve proper operation. For any questions, or to learn more, please contact Coto Technology.

6.2 Magnetic Response Table (LGA-4 package)

	Step 1: Sensor is powered without magnetic field.	Step 2: Magnet applied, polarity North .	Step 3: Magnet removed.	Step 4: Magnet applied, polarity South .	Step 5: Magnet removed.
Scenario					
OMNIPOLAR SENSOR OUTPUT	HIGH	LOW (Activated)	HIGH	LOW (Activated)	HIGH

Note: For details on the latch control pin functionality, please refer to sections 7.4 and 7.5.

6.3 Magnetic Response Output Diagram

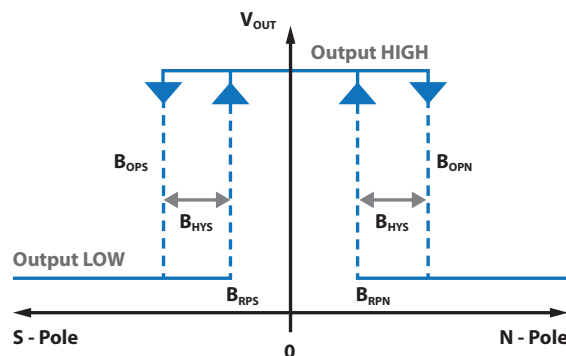

For more information, please contact Coto Technology at www.cotorelay.com.

7 Application Information

A decoupling capacitor with a minimum value of 0.1µF connected between V_{DD} and ground, placed not more than 10 mm from the sensor, is required.

7.1 Application – Signaling

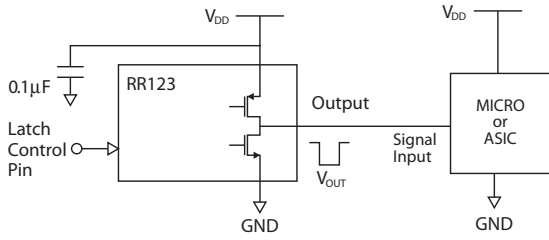

Magnet Present: Application microprocessor or ASIC is signaled by a logic-low signal.

Magnet Absent: Application microprocessor or ASIC is signaled by a logic-high signal.

7.2 Application – Power Switching

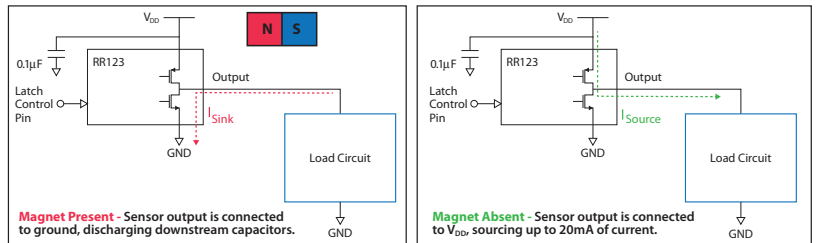

Magnet Present: The Load Circuit is driven to ground, discharging any circuit capacitors. Maximum sinking current is 100 µA.

Magnet Absent: The Load Circuit is powered by sourcing up to 20mA of current. The output design is optimized to source application circuit current in an efficient manner (Low R_{DS(on)}) while minimizing off-state leakage which increases I_{ddAVG}.

7.3 Package Pinout (LGA-4)

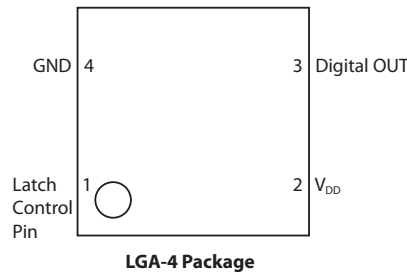

7.4 Output Locking Via Latch Control Pin (LCP)

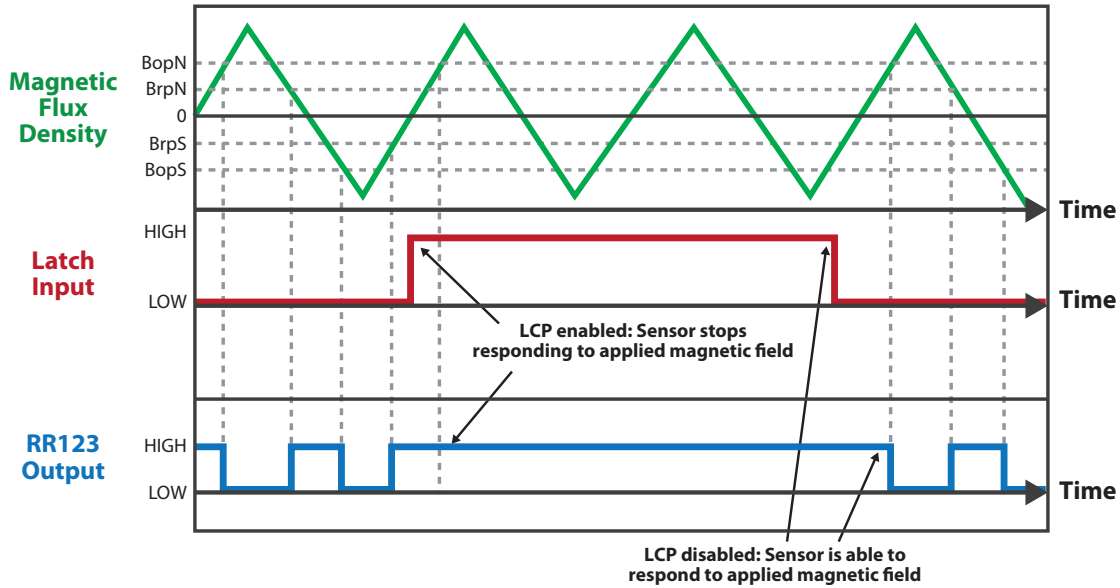

Latch Control Pin (LCP) Operation

As shown in the graph above, for as long as the LCP is enabled (i.e., driven to a logic HIGH), the RR123 Output will maintain whichever state it is in (i.e., Output HIGH or Output LOW) regardless of the presence or absence of a magnetic field. Once the LCP is disabled (driven to a logic LOW), the sensor can once again respond to an applied magnetic field.

When the LCP is not used (either temporarily or when not used at all), it is recommended to drive this pin to VSS (Ground) to avoid erroneous behavior caused by a residual charge in the LCP input capacitance.

Note: The enabling/disabling of the LCP does NOT increase the sensor's average current consumption.

7.5 Output Response Table

Initial State of Output	Magnetic Field Is ...	Latch Control Pin	Output
HIGH	Applied ($B > B_{OPN}$ or $B < B_{OPS}$)	LOW	Goes LOW
LOW	Removed ($B < B_{RPN}$ or $B > B_{RPS}$)	LOW	Goes HIGH
HIGH	Applied ($B > B_{OPN}$ or $B < B_{OPS}$)	HIGH	Stays HIGH
LOW	Removed ($B < B_{RPN}$ or $B > B_{RPS}$)	HIGH	Stays LOW

8 Dimensions *Millimeters (Inches)*

8.1 LGA-4 Package

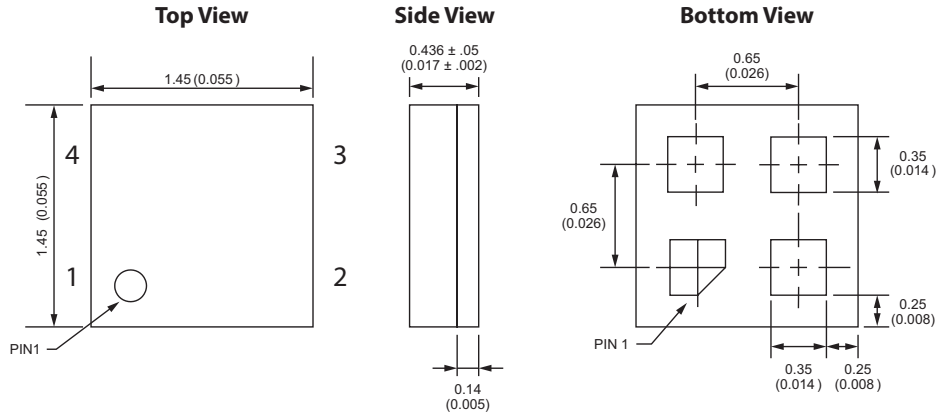

9 TMR Sensor Location

9.1 LGA-4 Package - Top View

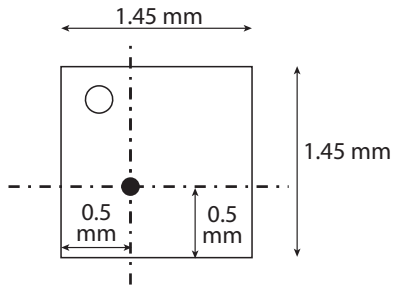

9.2 LGA-4 Package - Side View



10 Suggested Pb-Free Reflow Profile

Notes:

1. Fully compatible with standard no-lead solder profile, 260°C for 30 seconds max (3 cycles max).
2. Profile shown as example. Users are advised to develop their own board-level profile.
3. Suggested Pb-free reflow profile derived from IPC/JEDEC J-STD-020E.
4. Temperature tolerance: +0°C, as measured at any point on the package or leads
5. MSL rating of 3 (LGA-4) compatible with J-STD-020 or equivalent.
6. All temperatures refer to the center of the package, measured on the package body surface that is facing up during assembly reflow (e.g., live-bug). If parts are reflowed in other than the normal live bug assembly reflow orientation (i.e., dead-bug), T_p shall be within $\pm 2^\circ\text{C}$ of the live bug T_p and still meet the T_c requirements, otherwise, the profile shall be adjusted to achieve the latter. To accurately measure actual peak package body temperatures, refer to JEP140 for recommended thermocouple use.
7. Reflow profiles in this document are for classification/preconditioning and are not meant to specify board assembly profiles. Actual board assembly profiles should be developed based on specific process needs and board designs and should not exceed the parameters in this table.

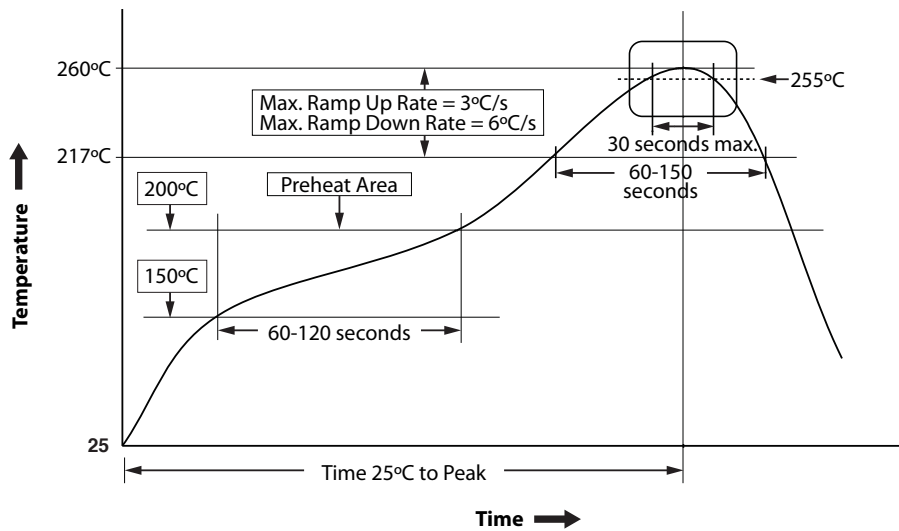

11 Suggested Solder Pad Layout

11.1 LGA-4 Solder Pad Layout

Dimensions in mm (inches)

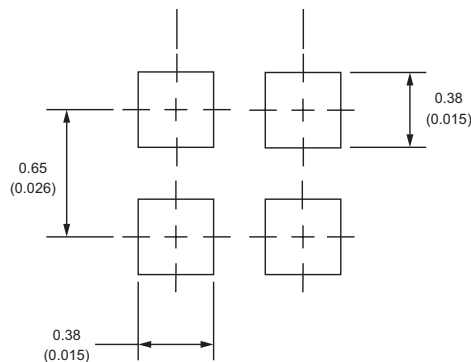

12 TMR Sensor & Switch Packaging

12.1 LGA-4 Tape & Reel Packaging

Standard packaging is Tape & Reel containing 3,000 pieces. MSL Rating is 3.

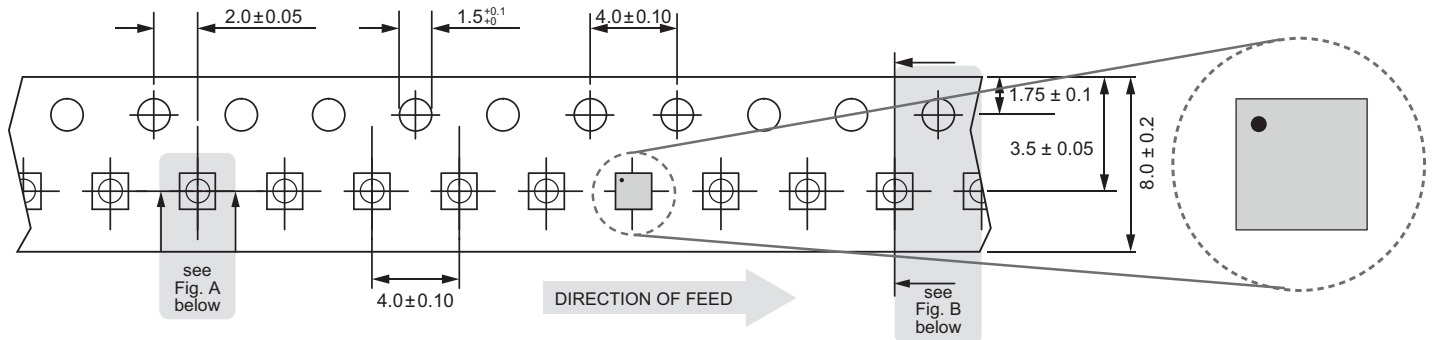

Fig. A

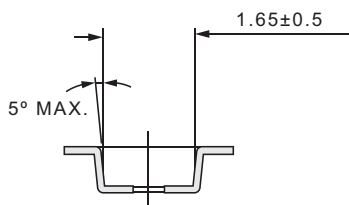
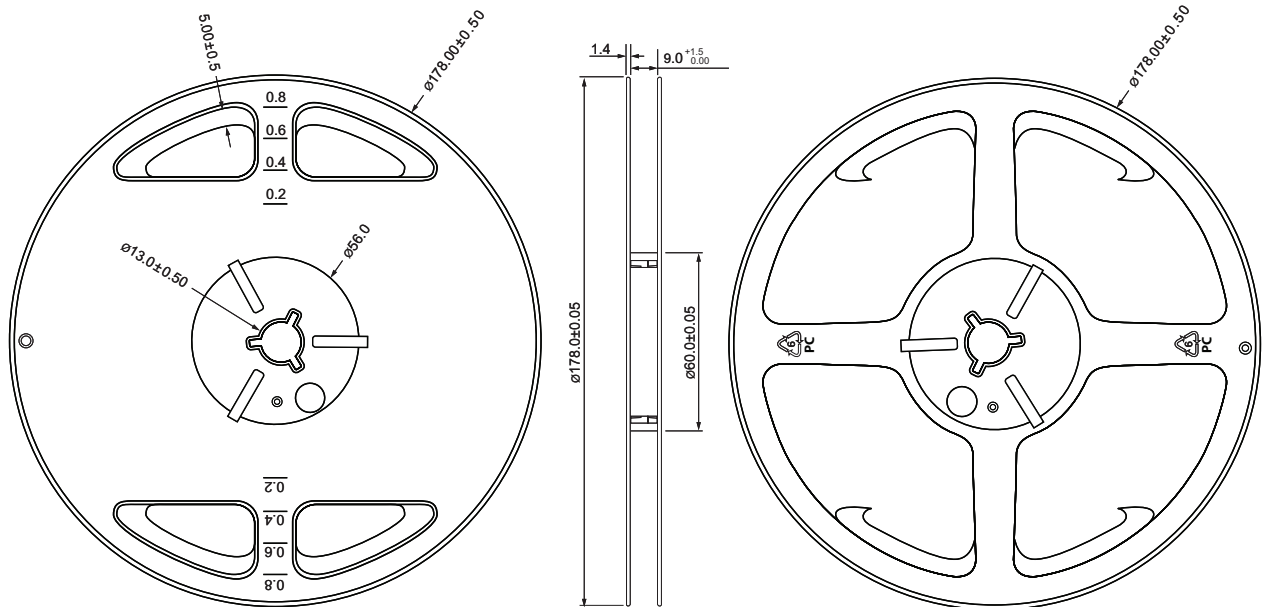
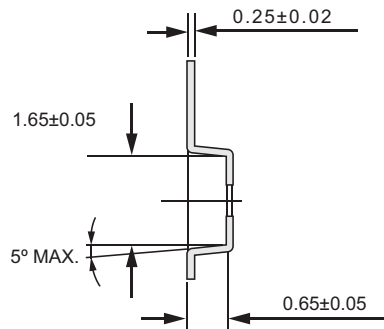

Fig. B



13 TMR Sensor & Switch Packaging

13.3 RedRock Package Code

RR123-1H02-612 (LGA-4)

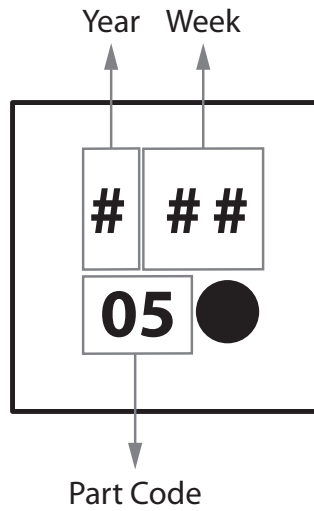

14 IMPORTANT NOTICE AND DISCLAIMER

COTO TECHNOLOGY, INC. ("COTO") PROVIDES THIS DATA SHEET "AS IS" AND WITH ALL FAULTS, AND DISCLAIMS ANY AND ALL WARRANTIES, EXPRESS AND IMPLIED, WITH RESPECT TO INFORMATION SET FORTH HEREIN, INCLUDING, WITHOUT LIMITATION, ANY IMPLIED WARRANTIES OF ACCURACY, COMPLETENESS, MERCHANTABILITY, FITNESS FOR A PARTICULAR PURPOSE AND NON-INFRINGEMENT OF THIRD-PARTY INTELLECTUAL PROPERTY RIGHTS. Your receipt of this data sheet constitutes your acknowledgement and acceptance of, and agreement to, all of the terms, conditions, notes, notices, disclaimers and limitations set forth herein.

This data sheet is subject to change without notice. Coto reserves the right to make, from time to time, changes to specifications set forth herein as may be necessary or desirable to improve the performance, reliability and/or manufacturability of the products described herein. As such, before placing an order of any Coto product described herein, you must verify that the information set forth herein is current with respect to such product, and Coto assumes no responsibility for any damages which you may incur due to your failure to do so.

Coto grants you permission to use this data sheet only for information and reference purposes, and any other use of this data sheet by you is prohibited. No license to any intellectual property right of Coto or any third party is granted hereunder.

You are solely responsible for (1) deciding whether to purchase or use any Coto product, (2) selecting appropriate Coto products for your application, (3) designing, validating and testing your application incorporating or involving any Coto product and (4) ensuring that such application meets applicable safety, security, regulatory or other requirements or standards. Any purchase or use of any Coto product must fully comply with all applicable laws and regulations, including, without limitations, import and export regulations.

Coto products described herein have been designed, developed and manufactured to be used in the standard commercial applications similar to those shown herein ("Specific Applications"). Any application requiring measures of reliability, robustness, safety or certifications not shown or beyond those shown herein is at the user's risk and is not warranted or guaranteed by Coto. Therefore, you are advised to use Coto products described herein only in Specific Applications.

Your purchase and use of Coto products, including, without limitation, those products described herein, are subject to Coto's terms and conditions of sale and other applicable terms available on Coto's website or otherwise provided or made available in conjunction with such products. Unless such terms and conditions state otherwise, COTO PRODUCTS ARE PROVIDED "AS IS" AND WITH ALL FAULTS, AND ANY AND ALL WARRANTIES, EXPRESS AND IMPLIED, WITH RESPECT TO SUCH PRODUCTS, INCLUDING, WITHOUT LIMITATION, ANY IMPLIED WARRANTIES OF MERCHANTABILITY, FITNESS FOR A PARTICULAR PURPOSE AND NON-INFRINGEMENT OF THIRD-PARTY INTELLECTUAL PROPERTY RIGHTS, ARE DISCLAIMED. Coto's provision of this data sheet does not expand or otherwise alter Coto's applicable warranties or warranty disclaimers for Coto products.

Coto disclaims responsibility for, and you will fully defend, indemnify and hold harmless Coto, its affiliates and its and their respective equity holders, directors, officers, employees, representatives, agents, successors and assigns against and for, any and all claims, damages, costs, losses and liabilities arising out of your use of this data sheet or your purchase or use of any Coto product described herein.